



US010059503B2

(12) **United States Patent**
Stuart

(10) **Patent No.:** **US 10,059,503 B2**

(45) **Date of Patent:** **Aug. 28, 2018**

(54) **CONTOURED ICE PACK SYSTEM FOR A FISH BODY**

7,427,001 B1 * 9/2008 Keitges B65D 81/382
220/4.24

8,621,885 B1 * 1/2014 Niebolte F25D 31/002
62/457.4

(71) Applicant: **Kevin R Stuart**, Kissimmee, FL (US)

2005/0235683 A1 * 10/2005 Fiene F25D 3/08
62/457.5

(72) Inventor: **Kevin R Stuart**, Kissimmee, FL (US)

(*) Notice: Subject to any disclaimer, the term of this patent is extended or adjusted under 35 U.S.C. 154(b) by 92 days.

FOREIGN PATENT DOCUMENTS

CN 202657464 1/2013
EP 1010957 6/2000
EP 1591732 * 11/2005 F25D 3/08

(21) Appl. No.: **14/701,501**

(22) Filed: **Apr. 30, 2015**

(65) **Prior Publication Data**

US 2016/0316772 A1 Nov. 3, 2016

(51) **Int. Cl.**

F25D 3/08 (2006.01)

B65D 81/38 (2006.01)

B65D 25/04 (2006.01)

(52) **U.S. Cl.**

CPC **B65D 81/3813** (2013.01); **B65D 25/04** (2013.01); **B65D 81/382** (2013.01); **F25D 3/08** (2013.01); **F25D 2303/082** (2013.01)

(58) **Field of Classification Search**

CPC B65D 81/382; F25D 2303/082; F25D 3/08
See application file for complete search history.

(56) **References Cited**

U.S. PATENT DOCUMENTS

D268,074 S 3/1983 Burg et al.
5,377,855 A 1/1995 Cook, Jr. et al.
5,901,571 A * 5/1999 Whaley F25D 3/08
62/457.5
6,185,860 B1 2/2001 Thibodeaux
7,389,608 B1 6/2008 MacKay

OTHER PUBLICATIONS

alltackle.com, Sea Angler Fish and Bait Soft Cooler Bags, viewed at: http://www.alltackle.com/sea_angler_fish_bags.html on Jan. 31, 2015.

Rubbermaid, Lunch Blox Sandwich Kit, viewed at: <http://www.rubbermaid.com/en-US/lunchblox%E2%84%A2-sandwich-kit> on Feb. 2, 2015.

Outdoorsmadeeasy, Grizzly 75qt Individual Ice Packs, viewed at: http://outdoorsmadeeasy.com/store/index.php?route=product/product&product_id=608 on Feb. 2, 2015.

amazon.com, 6 Pack Freez Kollant Can Cooler Pack Gel Cold Ice Substitute Hold 6 Soda Beer 2Pc, viewed at: <http://www.amazon.com/Pack-Freez-Kollant-Cooler-Substiute/dp/B00CKZ9DBK> on Jan. 31, 2015.

* cited by examiner

Primary Examiner — Orlando E Aviles Bosques

(74) *Attorney, Agent, or Firm* — Law Office of Steven R. Olsen, PLLC; Steven R. Olsen

(57) **ABSTRACT**

Embodiments of the invention provide rigid (hard-sided) ice packs that include contours configured to cooperate with whole fish, as harvested. The contours allow the fish to have close contact with surfaces of the ice pack while also protecting the fish from being bruised, crushed, deformed, or otherwise damaged during storage or transportation.

7 Claims, 7 Drawing Sheets

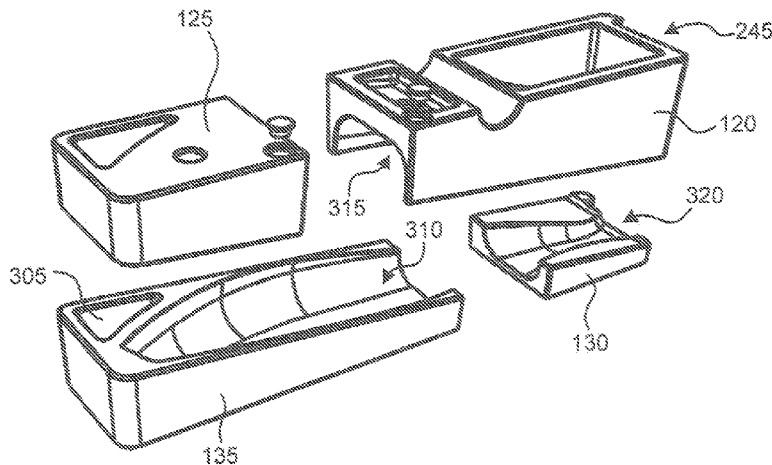

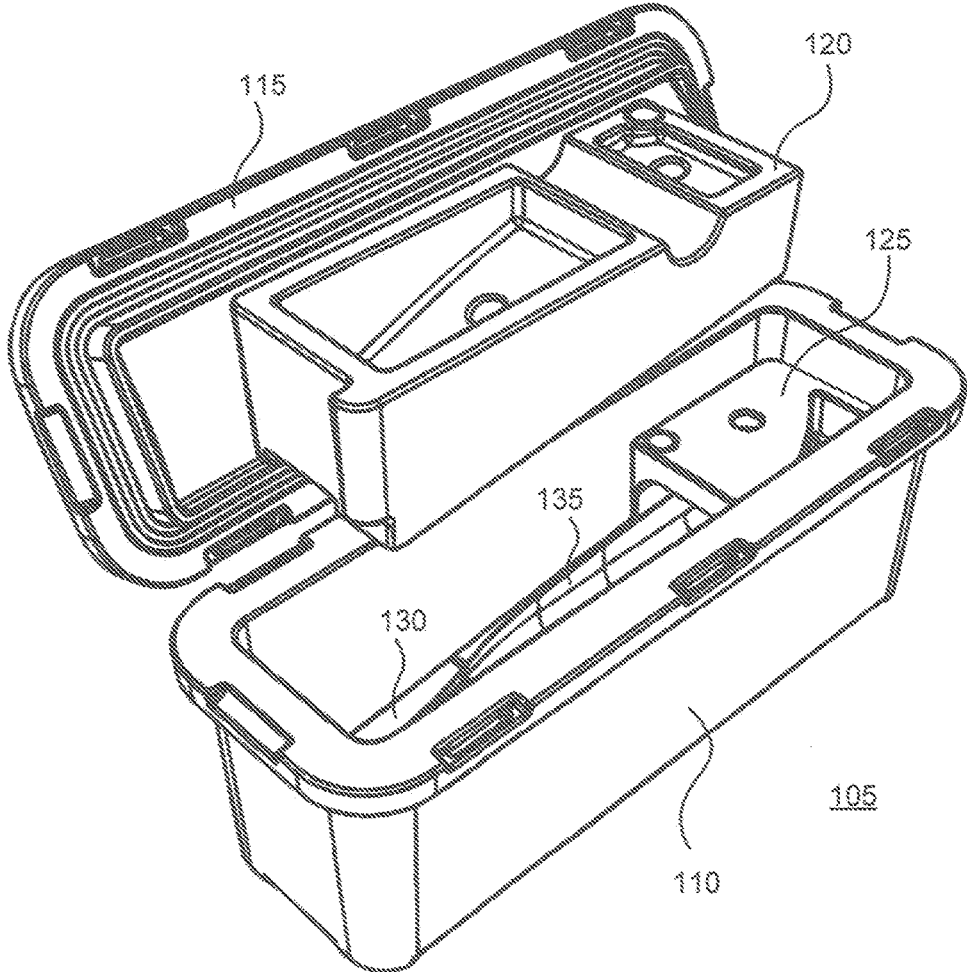

FIG. 1

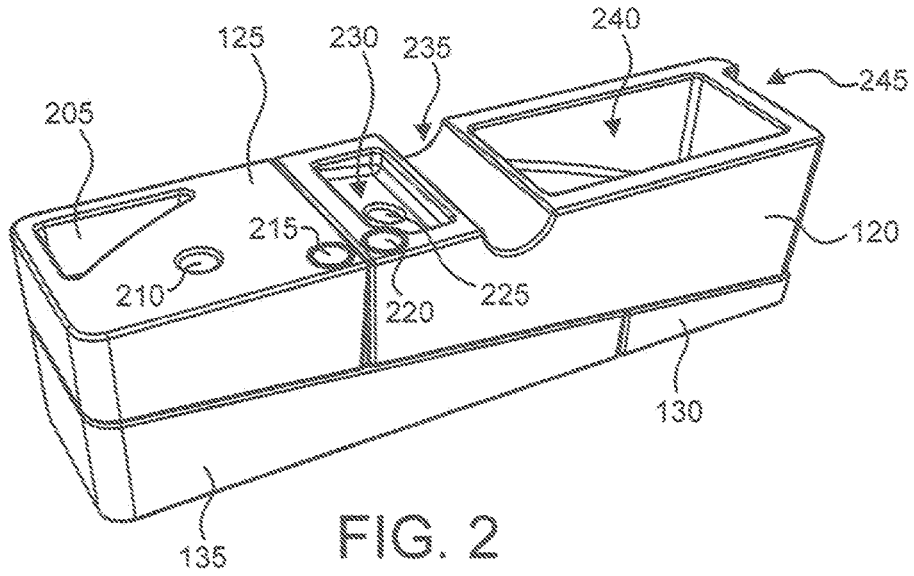

FIG. 2

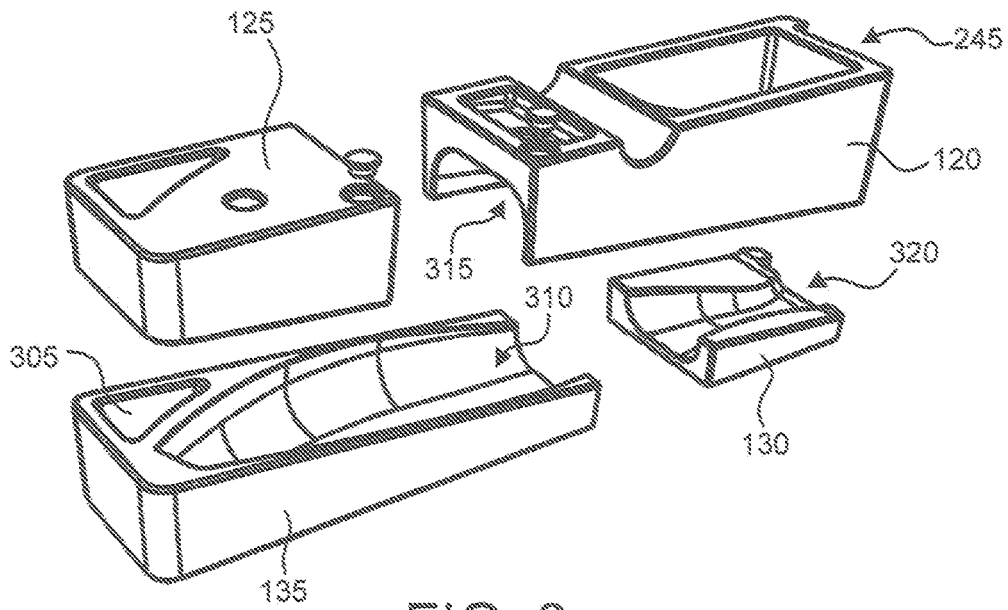

FIG. 3

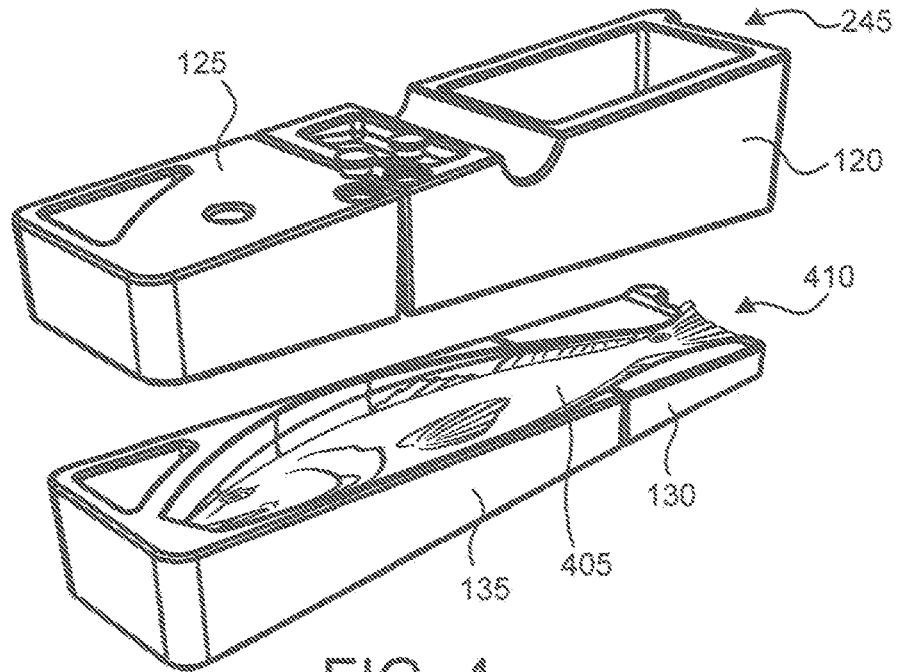

FIG. 4

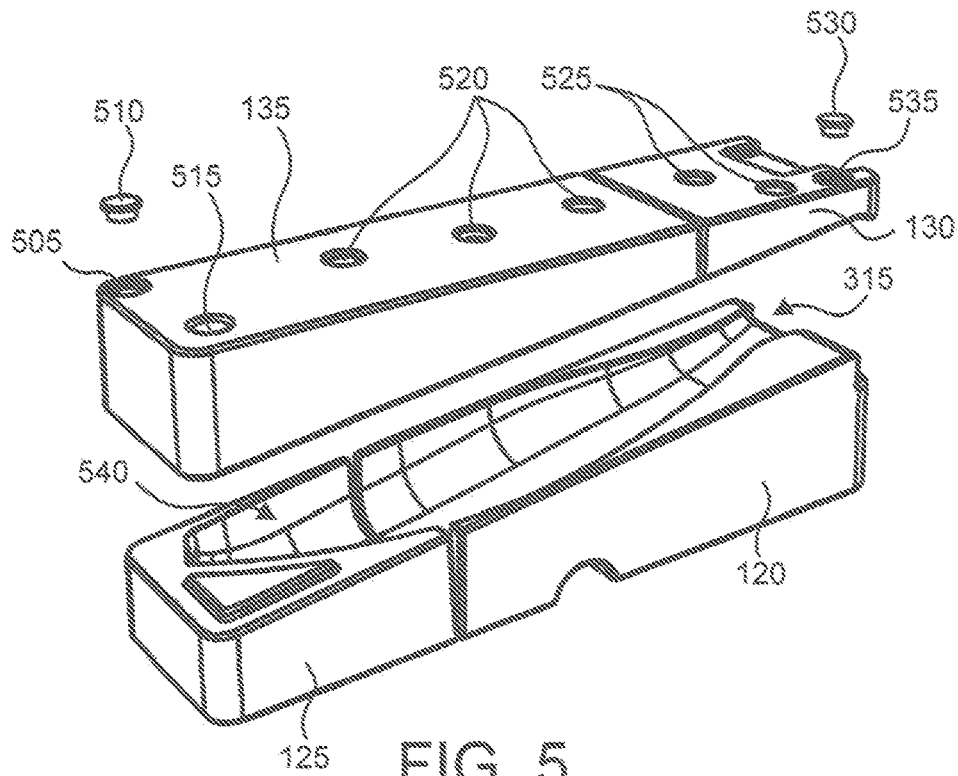
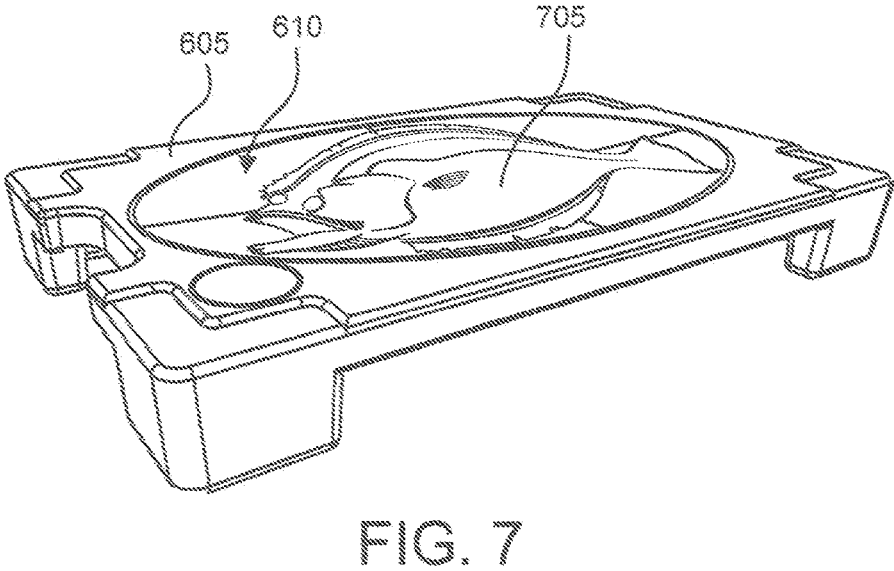
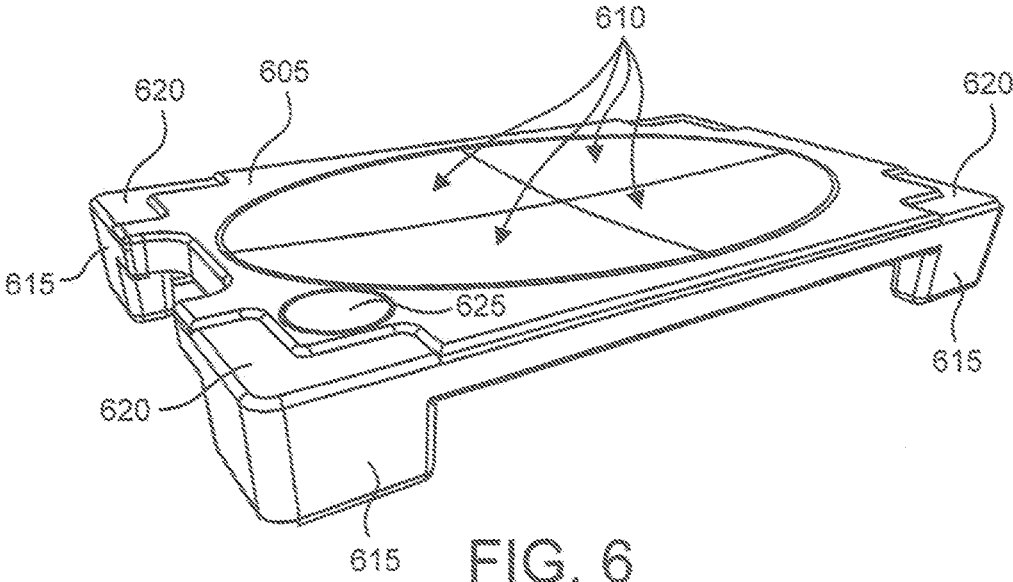

FIG. 5



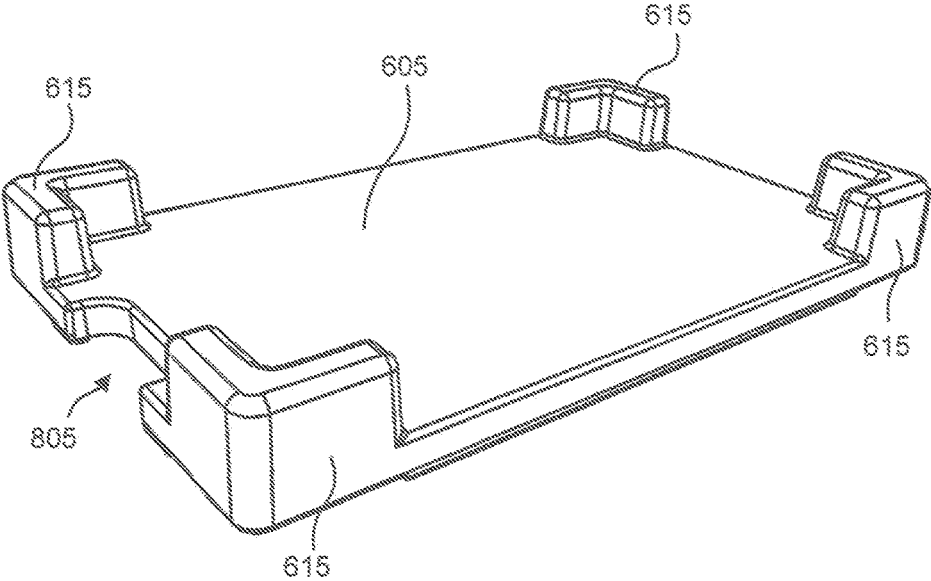

FIG. 8

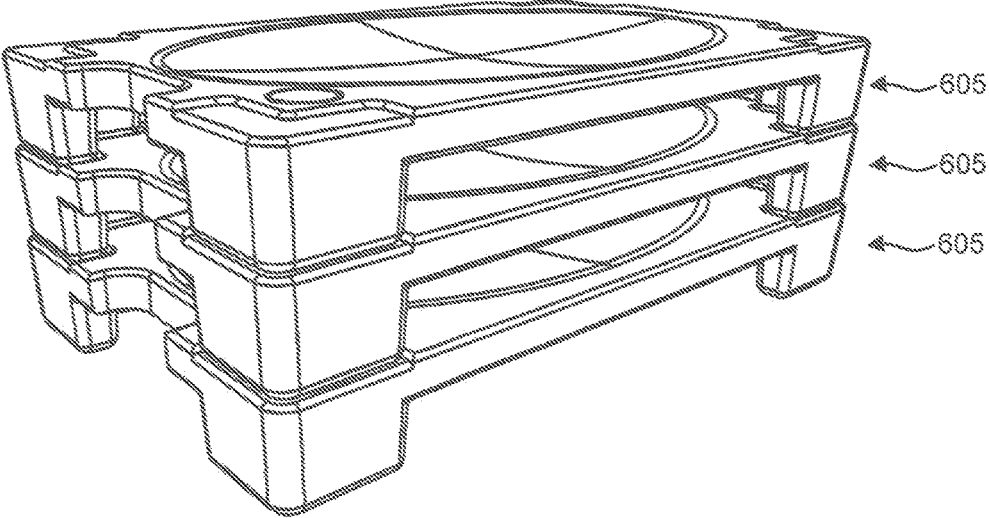

FIG. 9

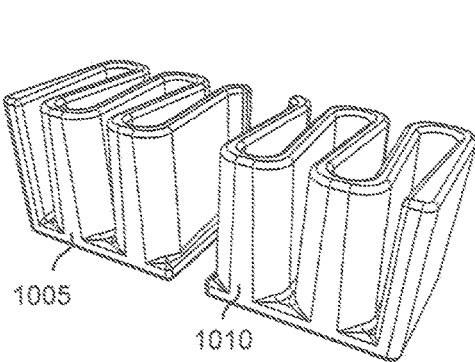

FIG. 10

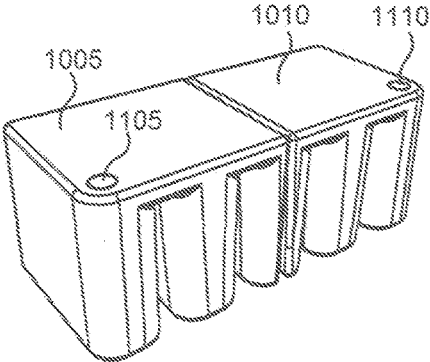

FIG. 11

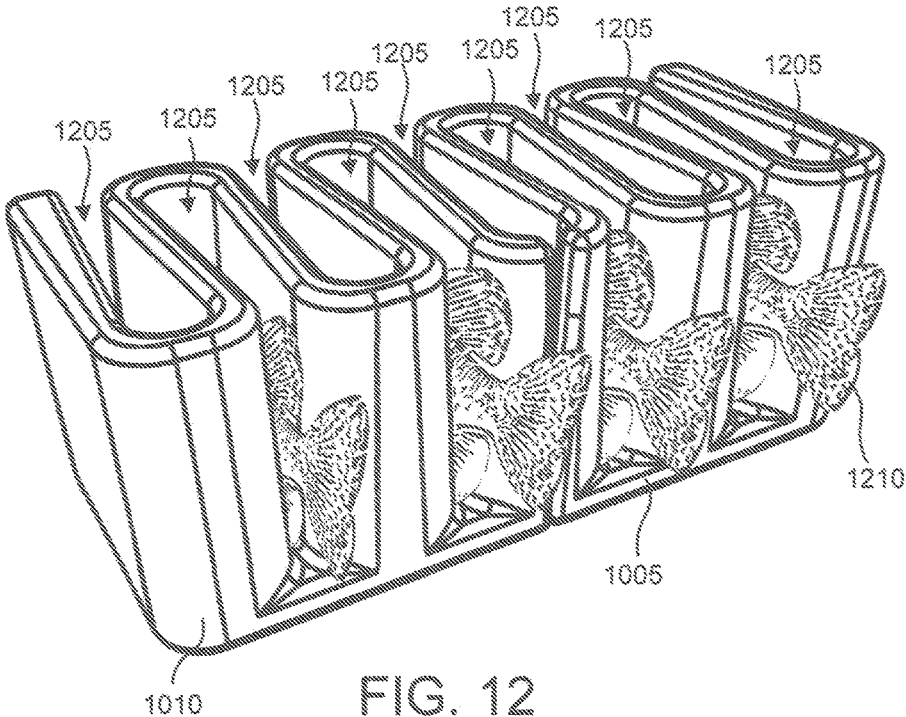

FIG. 12

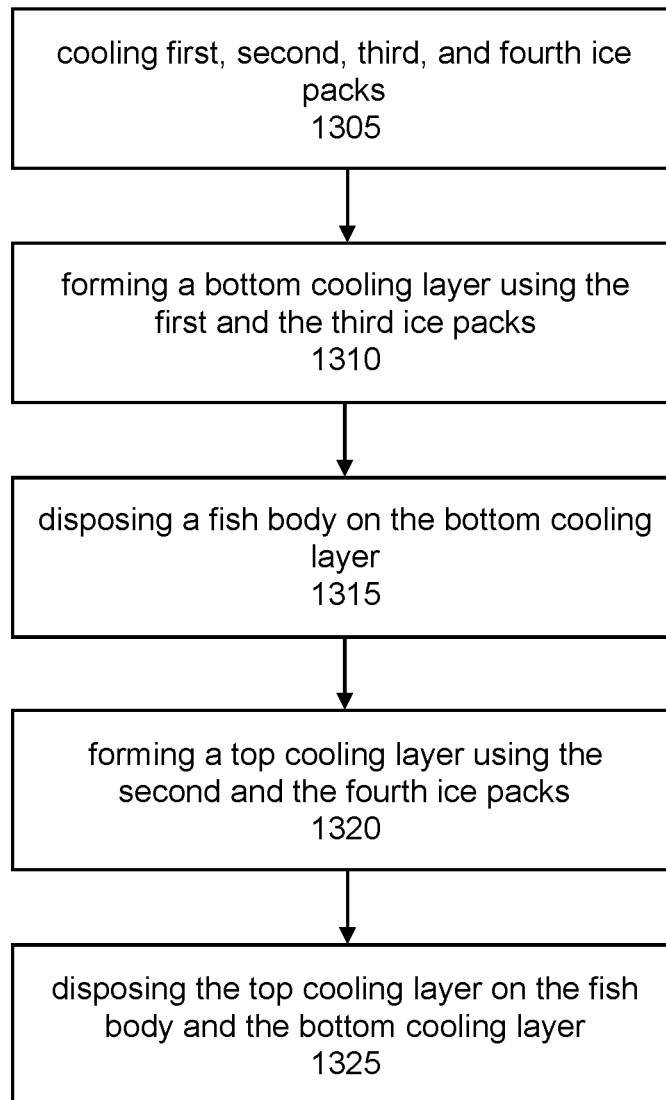

FIG. 13

CONTOURED ICE PACK SYSTEM FOR A FISH BODY

BACKGROUND

Field of Invention

The invention relates generally to refrigeration. In particular, but not by way of limitation, the invention relates to reusable ice packs that can be used to store or transport fish in a cooler or other insulated container.

Description of the Related Art

Many varieties of ice packs (*a/k/a* cooler packs or gel packs) are known. Such containers are typically reusable, and may be filled, for example, with water (with or without propylene glycol, alcohol, and/or other additives) or a refrigerant gel. Prior to use, a filled ice pack is placed in a freezer. Once the contents of the ice pack are frozen, the ice pack can be used, for instance, in a cooler or other insulated container to temporarily keep perishable foods or other items cool.

Conventional ice packs have some disadvantages, however. One shortcoming is that ice packs are typically brick-shaped and rigid. As a consequence, certain perishable foods (such as fresh fish) can be easily bruised, crushed, or otherwise damaged when being cooled by ice packs. In addition, the effects of rigor mortis can leave fish in a curled state, which makes filleting or other processing more difficult. Such risks are not mitigated by soft-sided ice packs because fish can be crushed or bent under the weight of such ice packs and/or other cooler contents. An improved device is needed for temporarily cooling fish or other fragile items.

SUMMARY OF THE INVENTION

The invention seeks to overcome one or more of the limitations described above. Embodiments of the invention provide rigid (hard-sided) ice packs that include contours configured to cooperate with whole fish, as harvested. The contours allow the fish to have close contact with surfaces of the ice pack while also protecting the fish from being bruised, crushed, deformed, or otherwise damaged during storage or transportation. These and other features and benefits are more fully described in the detailed description section below.

BRIEF DESCRIPTION OF THE DRAWINGS

Embodiments of the invention are described with reference to the following drawings, wherein:

FIG. 1 is a perspective view of a red drum fish ice pack system according to a first embodiment of the invention;

FIG. 2 is a perspective view of the red drum fish ice pack system according to the first embodiment of the invention;

FIG. 3 is a perspective view of the red drum fish ice pack system according to the first embodiment of the invention;

FIG. 4 is a perspective view of the red drum fish ice pack system according to the first embodiment of the invention;

FIG. 5 is a perspective view of the red drum fish ice pack system according to the first embodiment of the invention;

FIG. 6 is a perspective view of a flounder ice pack according to a second embodiment of the invention;

FIG. 7 is a perspective view of the flounder ice pack according to the second embodiment of the invention;

FIG. 8 is a perspective view of the flounder ice pack according to the second embodiment of the invention;

FIG. 9 is a perspective view of a stack of flounder ice packs according to the second embodiment of the invention;

FIG. 10 is a perspective view of two crappie ice packs according to a third embodiment of the invention;

FIG. 11 is a perspective view of a two crappie ice packs according to the third embodiment of the invention;

FIG. 12 is a perspective view of two crappie ice packs according to the third embodiment of the invention; and

FIG. 13 is a flow diagram of a method for using an ice pack system, according to an embodiment of the invention.

DETAILED DESCRIPTION

Embodiments of the invention are described below with reference to FIGS. 1-12. Reference designators are reused for the same or similar features. The drawings are not necessarily to scale. Some features illustrated in the drawings may be exaggerated for descriptive clarity.

Red Drum Fish Embodiment

FIGS. 1-5 provide perspective views of a red drum fish ice pack system according to a first embodiment of the invention. As illustrated in FIG. 1, a marine cooler 105 contains four ice packs 120, 125, 130, and 135 within its thermally-insulated cooler body 110 and lid 115. Each of the four ice packs 120, 125, 130, and 135 are preferably substantially rigid plastic (e.g., blow molded high-density polyethylene) containers and can be filled, for example, with water (with or without propylene glycol, alcohol, and/or other additives) or a refrigerant gel. As used herein, being substantially rigid means the container will hold its shape under normal use. In use, the contents of each ice pack 120, 125, 130, and 135 can be frozen (or at least cooled) prior to use as heat-absorbing devices in the marine cooler 105.

FIG. 2 shows that the ice packs 120, 125, 130, and 135 cooperate to form a single assembly. Ice packs 120 and 125 form a top cooling layer; ice packs 130 and 135 form a bottom cooling layer. In the illustrated embodiment, each of the ice packs 120, 125, 130, and 135 has a distinct different length (“different” meaning as compared to each of the other ice packs; “length” referring to a longest dimension).

In the illustrated embodiment, ice pack 125 includes a storage compartment 205, thumb hole 210, and filler cap 215. Ice pack 120 includes a filler cap 220, thumb hole 225, storage compartments 230, 235, and 240, and a recess 245. Each of the storage compartments 205, 230, and 240 can be used, for instance, to store snack food or bait. The storage compartment 235 is shaped to cradle a can or bottle. The thumb holes 210, 225 facilitate removal of the ice packs from the marine cooler 105. In embodiments of the invention, the filler caps 215, 220 may be permanently sealed, for instance after refrigerant gel has been added during manufacturing; in other embodiments, the filler caps 215, 220 may be threaded for convenient insertion into and removal from associated holes in the ice packs 125, 120. The purpose of the recess 245 will be described below with reference to FIG. 4.

FIG. 3 is an exploded view of the ice pack assembly. Partitioning the top cooling layer into ice packs 120, 125 and the bottom cooling layer into ice packs 130, 135 permits each ice pack to be a relatively small size. The relatively small size may be advantageous when cooling each of the ice packs 120, 125, 130, 135, for instance, in the freezer compartment of a residential refrigerator prior to use. FIG. 3 also illustrates a storage compartment 305 and a concave contour 310 in the ice pack 135, a concave contour 320 in

3

the ice pack **130**, and a concave contour **315** in the ice pack **120**. A concave contour **540** (visible in FIG. **5**) also exists in the ice pack **125**.

FIG. **4** illustrates a red drum fish **405** cradled by the concave contours **310** and **320**. Concave contours **315** and **540** keep cooling surfaces of the ice packs **120**, **125** close to a top surface of the red drum fish **405**, while also providing a protective canopy to minimize bruising, crushing, or undesirable deformation of the fish body. FIG. **4** thus illustrates that each of the contours **310**, **320**, **315**, and **540** have a shape that is complementary with respect to a corresponding portion of the red drum fish **405**. In the case of a large red drum fish **405** (larger than the one illustrated in FIG. **4**), a tail end **410** of the red drum fish **405** may be folded into the recess **245** of the ice pack **120**. The illustrated concave contours **310**, **320**, **315**, **540** may be suitable for species of fish other than a red drum fish **405**, for example large and small mouth bass. In an alternative embodiment, each of the concave contours **310**, **320**, **315**, **540** could be altered to be complementary in shape with respect to a corresponding portion of another species of fish.

The perspective view in FIG. **5** illustrates a bottom side of each of the ice packs **120**, **125**, **130**, **135**. A bottom side of the ice pack **135** includes a filler hole **505**, cooperating filler cap **510**, and structural support features **515** and **520**. A bottom side of the ice pack **130** likewise includes a filler hole **535**, cooperating filler cap **530**, and structural support features **525**. In embodiments of the invention, the filler caps **510**, **530** may be permanently sealed in the corresponding hole, for instance after refrigerant gel has been added during manufacturing.

FIG. **13** is a flow diagram of a method for using an ice pack system, according to an embodiment of the invention. The illustrated method includes: cooling first, second, third, and fourth ice packs in step **1305**; forming a bottom cooling layer using the first and the third ice packs in step **1310**; disposing a fish body on the bottom cooling layer in step **1315**; forming a top cooling layer using the second and the fourth ice packs in step **1320**; and disposing the top cooling layer on the fish body and the bottom cooling layer in step **1325**.

Variations to the red drum fish embodiment illustrated in FIGS. **1-5** and described above are possible. For instance, in an alternative embodiment, the top layer formed by ice packs **120**, **125** could be constructed using a single ice pack or by using more than two ice packs, according to design choice. Likewise, in an alternative embodiment, the bottom layer formed by ice packs **130**, **135** could be constructed using a single ice pack or by using more than two ice packs. It may be possible to omit the concave contours in the ice pack(s) that form the top layer or in the ice pack(s) that form the bottom layer, so long as the concave contours of the opposing layer are sufficiently deep to avoid damage to the target fish. The quantity and shape of storage compartments **205**, **230**, **235**, **240**, and **305** could be varied, or omitted altogether, based on application needs. In other embodiments, the thumb holes **215**, **220** could be relocated or omitted. The need for internal structural support features **515**, **520**, and **525** could vary based on material choice and the thickness of ice pack walls.

Flounder Embodiment

FIGS. **6-9** provide perspective views of a flounder ice pack system according to a second embodiment of the invention. As illustrated in FIG. **6**, a top surface of an ice pack tray **605** includes a concave contour **610**, stacking

4

notches **620**, and a filler cap **625**. Legs **615** extend from a bottom surface of the ice pack tray **605**. The ice pack tray **605** is preferably a substantially rigid plastic (e.g., blow molded high-density polyethylene) container and can be filled, for example, with water (with or without propylene glycol, alcohol, and/or other additives) or a refrigerant gel. In use, the contents of ice pack tray **605** can be frozen (or at least cooled) prior to use as a heat-absorbing device in a cooler or other thermally-insulated container.

In embodiments of the invention, the filler cap **625** may be permanently sealed, for instance after refrigerant gel has been added during manufacturing; in other embodiments, the filler cap **625** may be threaded for convenient insertion into and removal from a cooperating filling hole (not shown) in the ice pack **605**. The purpose of the stacking notches **620** will be described below with reference to FIG. **9**.

FIG. **7** illustrates a flounder **705** cradled by the concave contour **610** of the ice pack tray **605**. The concave contours **605** may be suitable for species of fish other than a flounder **705**. In an alternative embodiment, the concave contours **605** could be altered to accommodate a species of fish other than flounder.

The perspective view in FIG. **8** illustrates a bottom side of the ice pack tray **605**, and identifies handhold **805** that facilitates installation and removal of the ice pack tray **605** from the cooler or other insulated container. Two or more ice pack trays **605** can be stacked as shown in FIG. **9**; the legs **615** of one ice pack tray **605** cooperate with the stacking notches **620** of another ice pack tray **605**. In use, legs **615** prevent a flounder that is disposed under an ice pack tray **605** from being bruised, crushed, or deformed in a way that would later complicate the fillet process.

Variations to the flounder embodiment illustrated in FIGS. **6-9** and described above are possible. For instance, in an alternative embodiment, handholds **805** may be disposed on two or more sides of the ice pack tray **605**. The handhold **805** could also be omitted, according to application demands. Other embodiments could use fewer than four legs, or more than four legs, to maintain spacing between stacked tray surfaces. In other embodiments, alternative stacking features, such as cooperating pins and holes, could be used in the place of stacking notches **620**.

Crappie Embodiment

FIGS. **10-12** provide perspective views of a crappie ice pack system according to a third embodiment of the invention. FIG. **10** illustrates two ice packs **1005**, **1010**, that can cooperate to form a single ice pack system. Each of the ice packs **1005**, **1010**, has a serpentine cross section. Each of the ice packs **1005**, **1010**, is preferably a substantially rigid plastic (e.g., blow molded high-density polyethylene) container and can be filled, for example, with water (with or without propylene glycol, alcohol, and/or other additives) or a refrigerant gel. In use, the contents of ice packs **1005**, **1010** can be frozen (or at least cooled) prior to use as a heat-absorbing device in a cooler or other thermally-insulated container.

As shown in FIG. **11**, a bottom surface of the ice pack **1005** includes a filler cap **1105**, and a bottom surface of the ice pack **1010** includes a filler cap **1110**. In embodiments of the invention, the filler caps **1105**, **1110** may be permanently sealed, for instance after refrigerant gel has been added during manufacturing; in other embodiments, the filler caps **1105**, **1110** may be threaded for convenient insertion into and removal from cooperating filling holes (not shown).

5

FIG. 12 illustrates that the serpentine cross section of the ice packs 1005, 1010, forms pockets 1205. Each of the pockets 1205 can both cool and protect a crappie 1210.

Variations to the crappie embodiment illustrated in FIGS. 10-12 and described above are possible. For example, in an alternative embodiment, the assembly with a serpentine cross section can be formed with a single ice pack having a serpentine cross section or with more than two such ice packs. In alternative embodiments, the dimensions and proportion of pockets 1205 could be varied to accommodate species of fish other than crappie, for instance blue gill.

Summary

Embodiments of the invention thus provide ice packs that are configured to both cool and protect fish or other fragile targets. Those skilled in the art can readily recognize that numerous variations and substitutions may be made in the invention, its use and its configuration to achieve substantially the same results as achieved by the embodiments described herein. For instance, materials other than plastic could be used to construct ice pack containers, and, in use, the disclosed ice packs can be filled with a variety of alternative heat exchange fluids, solids, or gels. Accordingly, there is no intention to limit the invention to the disclosed exemplary forms. Many variations, modifications and alternative constructions fall within the scope and spirit of the disclosed invention.

I claim:

1. An ice pack system for a fish body of a target fish species comprising:
 - a first ice pack, the first ice pack being substantially rigid, a surface of the first ice pack including a first contour, the first contour being concave and disposed on a top surface of the first ice pack, the first contour being a complementary shape with respect to a first portion of the fish body;
 - a second ice pack, the second ice pack being substantially rigid, a surface of the second ice pack including a second contour, the second contour being concave and disposed on a bottom surface of the second ice pack, the second contour being a complementary shape with respect to a second portion of the fish body;
 - a third ice pack, the third ice pack being substantially rigid, a surface of the third ice pack including a third contour, the third contour being concave and disposed on a top surface of the third ice pack, the third contour being a complementary shape with respect to a third portion of the fish body; and
 - a fourth ice pack, the fourth ice pack being substantially rigid, the fourth ice pack including a fourth contour, the fourth contour being concave and disposed on a bottom surface of the fourth ice pack, the fourth contour being a complementary shape with respect to a fourth portion

6

of the fish body, the first, second, third, and fourth contours being different from each other, the first and third ice packs cooperating to form a bottom layer in use, the second and fourth ice packs cooperating to form a top layer in use, such that the first, second, third, and fourth portions of the fish body can be disposed in a cavity formed by the first, second, third, and fourth contours.

2. The ice pack system of claim 1, further comprising:
 - a first storage compartment disposed in a top surface of the second ice pack; and
 - a second storage compartment disposed in a top surface of the fourth ice pack.
3. The ice pack system of claim 1, further comprising:
 - a first thumb hole disposed in a top surface of the second ice pack; and
 - a second thumb hole disposed in a top surface of the fourth ice pack.
4. The ice pack system of claim 1,
 - a first filler cap disposed in a bottom surface of the first ice pack;
 - a second filler cap disposed in a top surface of the second ice pack;
 - a third filler cap disposed in a bottom surface of the third ice pack; and
 - a fourth filler cap disposed in a top surface of the fourth ice pack.
5. The ice pack system of claim 1, wherein each of the first, second, third, and fourth ice packs has a different length.
6. The ice pack system of claim 1, wherein the target fish species is a red drum fish, the fish body being a red drum fish body, the first contour being a complementary shape with respect to a first portion of the red drum fish body, the second contour being a complementary shape with respect to a second portion of the red drum fish body, the third contour being a complementary shape with respect to a third portion of the red drum fish body, the fourth contour being a complementary shape with respect to a fourth portion of the red drum fish body.
7. A method for using the ice pack system of claim 1, comprising:
 - cooling each of the first, second, third, and fourth ice packs;
 - forming a bottom cooling layer using the first and the third ice packs;
 - disposing the fish body on the bottom cooling layer;
 - forming a top cooling layer using the second and the fourth ice packs; and
 - disposing the top cooling layer on the fish body and the bottom cooling layer, the method minimizing bruising of the fish body while disposed in the cavity.

* * * * *